

Please, read this manual
carefully before use!

Owner's Manual



Gasoline Cultivator

KS 4HP-45

KS 5HP-65

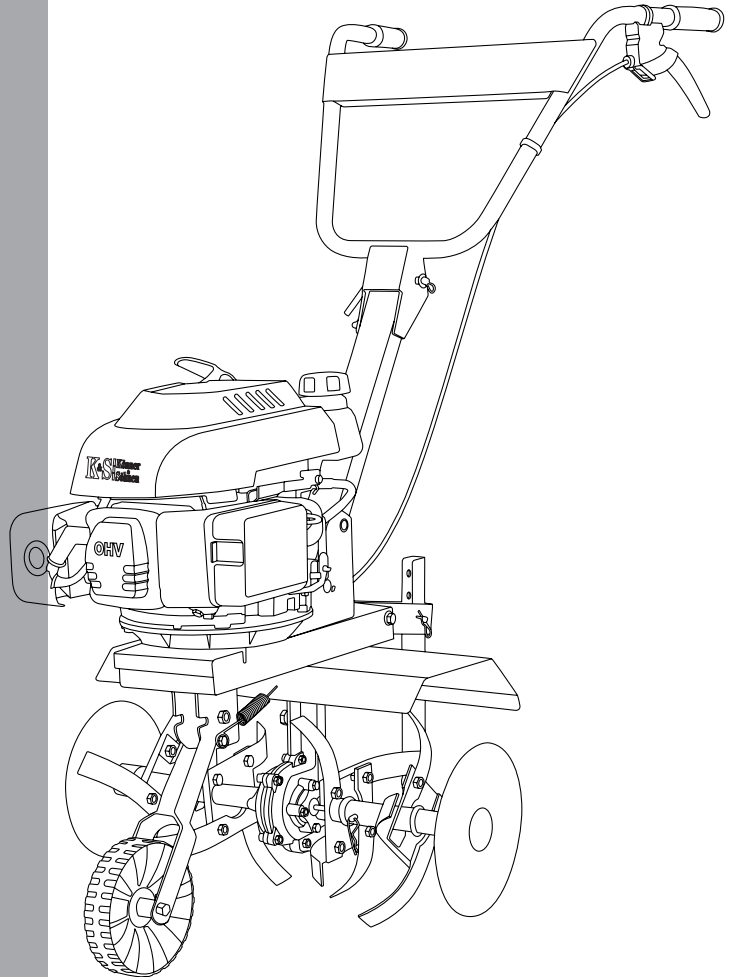

TABLE OF CONTENTS

1. Preface	2
2. Product Description	2
3. Specifications	3
4. Product Overview	4
5. Safety Precautions	5
6. Description of Symbols	7
7. Supply Package	9
8. Cultivator Assembly	12
9. Cultivator Operation	15
10. Maintenance	18
11. Troubleshooting	22
12. Transportation	23
13. Storage	23
14. Disposal	23

EXPLANATION OF SYMBOLS:

KS	TM Könnert & Söhnen products
4HP-45, 5HP - 65	model name
4, 5	cultivator power (hp)

Please read this manual carefully. Pay particular attention to information that starts with characters/words:



Failure to observe the recommendation marked with this sign may result in serious injury or death to the operator or third parties.



Useful information on the use of the device.

PREFACE

Thank you for your purchase of the gasoline cultivator from **TM Könnert & Söhnen**. This manual contains safety information and requirements for the use and maintenance of this product.

Before getting started, we strongly recommend that you familiarize yourself with the owner's manual. This will help you avoid personal injury and possible damage to the equipment. All information is up to date at the time of its publication, but some changes introduced by the manufacturer in the product may not be reflected in the owner's manual.



The manufacturer reserves the right to introduce changes in the product design, configuration and construction. Product images are for illustrative purposes only and may differ from the actual product.

For more information and details, please visit our official website.

www.ks-power.de

PRODUCT DESCRIPTION

All power cultivators from **Könnert & Söhnen** are equipped with the latest generation of high-performance OHV engines, which have the following features:

- Increased lifespan;
- High power rating at low weight;
- Low noise level compared to similar engines;
- Low fuel consumption.

Könnert & Söhnen cultivator features:

- Easy processing of even the toughest lumps and parts of soil thanks to forged saber-like cutters.
- Easy-to-adjust operator's panel.
- Plant protection during plowing due to plant shielding wheels.
- The package includes a transport wheel to facilitate transportation of the device and any cargo.

SPECIFICATIONS

Cultivator	KS 4HP-45	KS 5HP-65
Engine power, max. (HP)	4,0	5,0
Rated power (kW)	2,98	3,73
Engine	KS 100	KS 140
Engine capacity (ccm)	98	140
Plowing width (cm)	≤ 45	≤ 65
Plowing depth (cm)	≤ 26	≤ 26
Fuel tank capacity (L)	1,0	0,8
Oil crankcase capacity (L)	0,4	0,45
Cutter diameter, mm	260	260
Starter	Manual	Manual
Transmission drive	Belt	Belt
Gears	1	
Noise level at a distance of 7 m, dB	91	91
Net weight (kg)	31	33



PLEASE NOTE!



Recommended oil - SAE 10W30, SAE 10W40

PRODUCT OVERVIEW

KS 4HP-45, KS 5HP- 65

Fig. 1

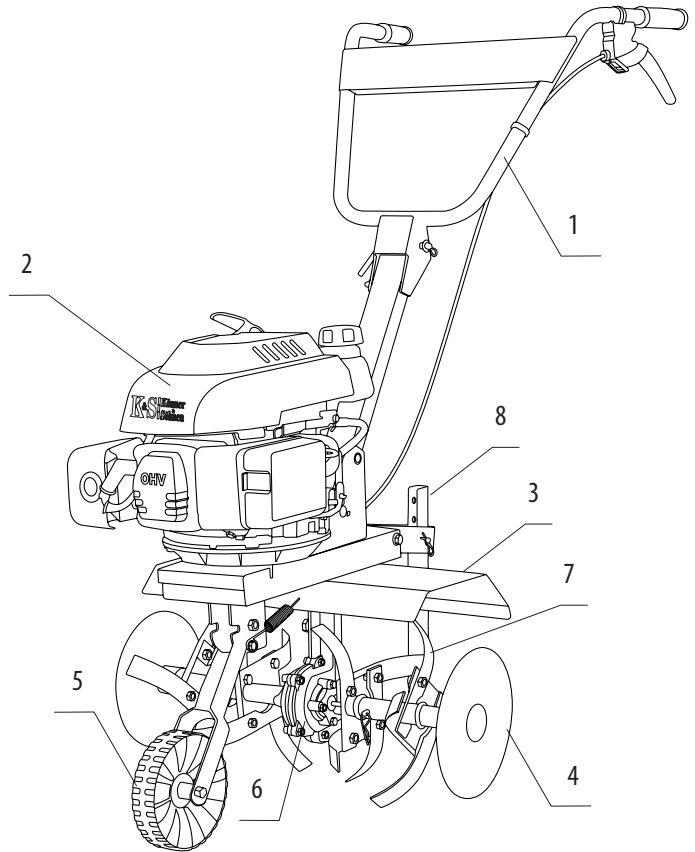

1. Operator's panel
2. Engine
3. Fenders
4. Plant shielding wheel
5. Transport wheel
6. Gearbox
7. Cutters
8. Coulter

SAFETY PRECAUTIONS

Before operating the cultivator, please carefully read the owner's manual. Do not allow unauthorized people and children to operate the device. Do not use the device in close proximity to the working area of adults, children and animals – the user of the cultivator is solely responsible for personal injury and property damage. The Könnert & Söhne power cultivator complies with the current European safety standards. Never attempt to make any changes to the design of the device.

OBSERVE THE FOLLOWING REQUIREMENTS WHEN OPERATING THE CULTIVATOR:

1. Before getting started, please carefully read the owner's manual. Keep the owner's manual in a safe place for future reference; follow the recommendations contained therein in order to avoid personal injury and property damage.
2. Familiarize yourself with the cultivator controls and functions. In case of an emergency, the operator must know how to stop the working parts of the cultivator and its engine.
3. The operator of the device must be in good physical and mental health and be quick in decisions, if necessary. Do not operate the cultivator under the influence of alcohol, drugs or medications that can slow down the reaction.
4. The cultivator is designed to cultivate soil when sowing, as well as to handle and process plants. Do not use the cultivator for purposes other than those initially intended.

OPERATING THE CULTIVATOR

The device should be turned on in accordance with the instructions in the owner's manual. Make sure the operator keeps a safe distance from the working parts of the cultivator. Never place your legs or arms on the rotating parts or underneath them. To lift the device, two people must grab the handles and shafts of the cultivator. Wear special safety gloves to protect your hands and safety shoes; do not operate the cultivator in open toe shoes.

CAUTION!

- The engine and exhaust pipe must be kept clean to avoid potential fire. Thoroughly check them for foliage, grass, and oil or fuel leaks.
- Watch out for the rotating parts. Do not touch the rotating cutters



WARNING - DANGER!



Note! Stop the engine before refueling, transportation and if the device should be left unattended.

OPERATING THE CULTIVATOR ON THE MOUNTAINOUS TERRAIN

1. Follow the correct positioning of the device on the slopes. The slope angle of 10% corresponds to a 10 cm lift per 100 cm horizontal plane. Never attempt to plow soil on steeper slopes in order not to lose control of the device.
2. When operating the device on slopes or mountainous terrain, be sure to install all the mills.
3. A person operating the cultivator must not stand below the device in order not to end up under the working cultivator if they lose control of it.
4. Do not operate the device across a slope. Only move forward, do not jerk the cultivator back and forth.
5. Be careful when changing the direction of the cultivator.
6. Slow down when on stony ground.
7. The cultivator should only be operated at the pace of a step since faster movement poses a tripping and slipping hazard, etc.
8. To adjust the running depth of the device, apply greater or lower pressure to the coulter handle.
9. Do not turn over the engine and do not change its main position!

GASOLINE USE AND STORAGE

Gasoline is an extremely toxic and flammable substance. Therefore, be sure to observe the following rules for its storage and use:

1. Only store fuel in hermetically sealed containers specially designed for this purpose. Keep the gasoline container in a cool, dark place away from sparks and open flames.
2. When the engine is running, the cultivator emits exhaust gases that can cause poisoning. Do not use the device in closed, poorly ventilated areas.
3. Refuel the cultivator outdoors before starting the engine. Do not open the fuel cap and add gasoline if the cultivator is still hot after work.
4. Ensure there is enough air space to allow for fuel expansion. Fill the fuel tank to approx. 4 cm below the lower edge of the tank filler neck. Do not fill the tank completely.
5. Carefully remove any spilled gasoline from the cultivator surface. Never start the engine until the gasoline vapors have evaporated and the surface is clean.
6. Always close the fuel cap tightly.
7. To empty the fuel tank completely, start the cultivator engine outdoors until the fuel is fully burnt.
8. Only transport the cultivator when the fuel tank is empty and the fuel valve is closed.
9. Allow the device to cool down before placing it in storage.
10. For safety reasons, do not leave the device indoors with gasoline in the fuel tank. Gasoline vapors can come into contact with sparks or open flames, which can cause vapors to ignite.
11. Check the device for damage and leaks in the fuel line, fuel tank and fuel cap, as well as for damage to the damper and protective plates on a regular basis. Replace parts, if necessary, in a timely manner.

MAINTENANCE AND REPAIR

When operating the cultivator on slopes, the slope angle should not exceed 10% (5.7°). Only operate the device in daylight or with adequate artificial lighting. Only use original spare parts to avoid personal injury and damage to the device; replace worn or damaged parts in a timely manner; tighten all bolts, screws and nuts as far as they will go.

Carry out only those maintenance work described in the owner's manual. Before maintaining the device, be sure to disconnect the spark plug wire. Works that are not intended for independent performance must be carried out by an authorized Könnert & Söhnen service center. A list of authorized service centers can be found on our official website www.ks-power.de.



WARNING - DANGER!



Fuel pollutes soil and groundwater. Avoid gasoline leaking out of the fuel tank!

DESCRIPTION OF SYMBOLS

K&S Könnert & Söhnen		Model:	KS 5HP-65
GASOLINE TILLER		CE	
GLEBOGRYZARKA BENZYNOWA			
MAX. ENGINE POWER, HP	5.0	—	Maximum engine power
MOC SILNIKA MAKSY, KM		—	Rated power
RATED POWER OF TILLER, kW	3.73	—	Engine model
MOC ZNAMIONOWA		—	Number of gears
GLEBOGRYZARKI, kW		—	Plowing width
ENGINE MODEL	KS 140	—	Plowing depth
MODEL SILNIKA		—	Weight
FORWARD SPEED	1	—	Date of manufacture
BIEG DO PRZODU		—	Serial number
WORKING WIDTH	≤ 65 cm		
SZEROKOSC OBROBKI			
WORKING DEPTH	≤ 26 cm		
GLEBOKOSC OBROBKI			
WEIGHT	33kg		
WAGA			
YEAR OF ISSUE	2018		
ROK PRODUKCJI			
SERIAL NUMBER NUMBER SERYJNY/S/N			
<small>Manufactured under license of DIMAX Int. GmbH, Hauptstr. 134, 51143, Cologne, Germany, www.ks-power.de Wyprodukowano na licencji DIMAX International GmbH, ul. Hauptstr. 134, 51143, Kolonia, Niemcy, zmont. w GPN, Importer do Polski: DIMAX International Poland Sp. z o.o., Szwarcowska 47, 02-682 Warszawa, Polska, www.ks-power.pl</small>			
Könnert & Söhnen, Germany			

- Maximum engine power
- Rated power
- Engine model
- Number of gears
- Plowing width
- Plowing depth
- Weight
- Date of manufacture
- Serial number

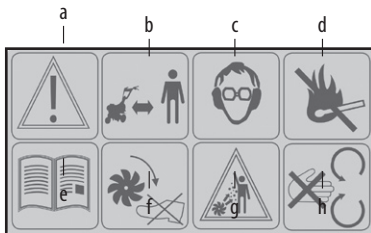

- a. Note! Important!
- b. Third parties must keep a safe distance from the running device;
- c. Wear safety goggles and earplugs;
- d. Do not operate the cultivator near open flames!
- e. Carefully read the owner's manual before getting started;
- f. Do not bring your legs to the rotating cutters;
- g. Do not stand in the working area of the cultivator;
- h. Do not bring your arms to the rotating parts of the cultivator.

CLUTCH SPRZĘGŁO

Clutch



Do not touch! The surface becomes hot during operation.



Crankcase capacity

Recommended oils



Noise level at a distance of 7 m



Position of the air choke handle (to start, set to "Closed" in the direction of the arrow)

Fuel valve (set to "Open" in the direction of the arrow)



Fill the oil tank to the required level only



Note on gasoline







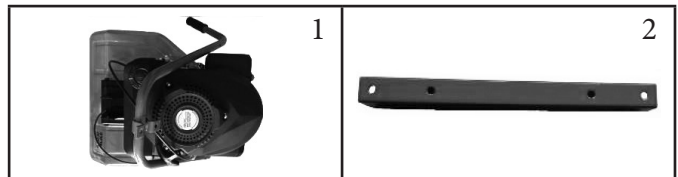

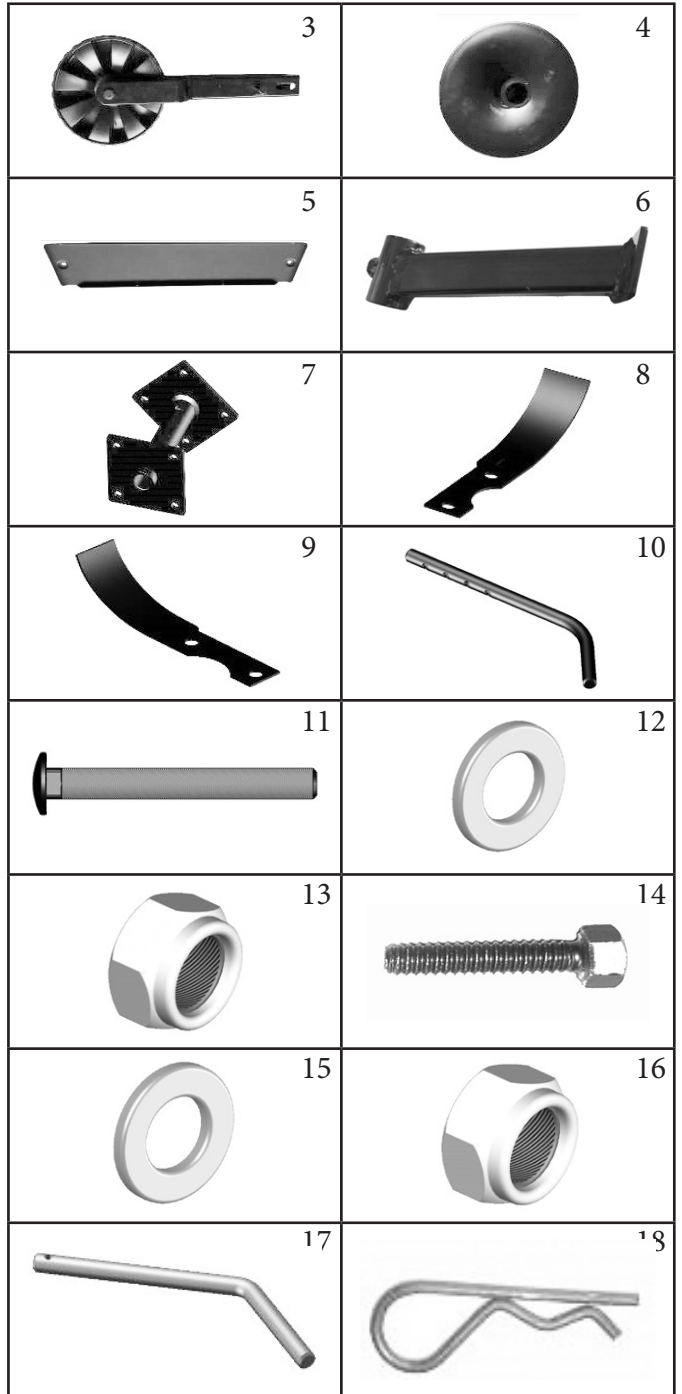







SUPPLY PACKAGE

1. Cultivator	1 pcs
2. Steering column	1 pcs
3. Transport wheel	1 pcs
4. Plant shielding wheel	2 pcs
5. Operator's panel protection	1 pcs
6. Coulter holder	1 pcs
7. Cutter shaft	2 pcs
8. Left-hand cutter	8 pcs
9. Right-hand cutter	8 pcs
10. Coulter	1 pcs
11. M6x35 screw	2 pcs
12. D6 washer	2 pcs
13. M6 nut	2 pcs
14. M8x70 screw	1 pcs
15. D8 washer	5 pcs
16. M8 lock nut	17 pcs
17. Operator's panel locking handle	1 pcs
18. Pin	5 pcs
19. M8x70 screw	2 pcs
20. M8 nut	3 pcs
21. M8x25 screw	2 pcs
22. D8 washer	2 pcs
23. Handle latch	1 pcs
24. Cable tie	3 pcs
25. M8x20 screw	16 pcs
26. Short pin	2 pcs
27. Long pin	2 pcs
28. M8x50 screw	1 pcs
29. Transport wheel spring	1 pcs
30. Left-hand fender	1 pcs
31. Right-hand fender	1 pcs
32. M6x12 screw	6 pcs
33. M6 nut	6 pcs
34. Cutter shaft assembly extension (par. 30-34 for models KS 5HP-65)	6 pcs

Fig. 2





 <p>19</p>	 <p>20</p>
 <p>21</p>	 <p>22</p>
 <p>23</p>	 <p>24</p>
 <p>25</p>	 <p>26</p>
 <p>27</p>	 <p>28</p>
 <p>29</p>	 <p>30</p>
 <p>31</p>	 <p>32</p>
 <p>33</p>	 <p>34</p>

ASSEMBLE THE CULTIVATOR AS SHOWN

ASSEMBLING THE CUTTERS

Fig. 3

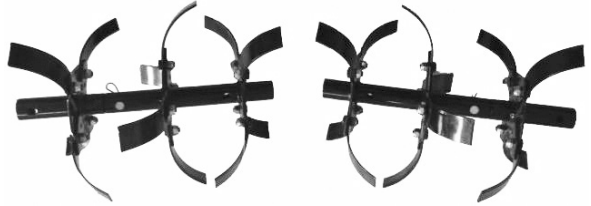

INSTALLING THE CUTTERS AND PLANT SHIELDING WHEELS

Fig. 4

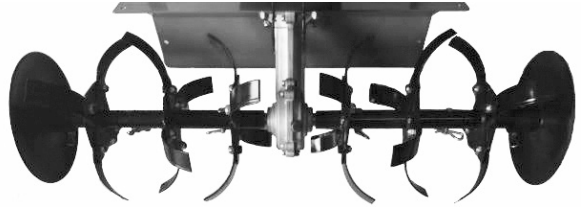

MOUNTING THE COULTER HOLDER

Fig. 5



MOUNTING THE COULTER



Fig. 6

MOUNTING THE STEERING COLUMN

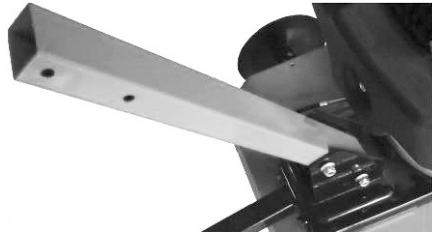

Fig. 7

MOUNTING THE OPERATOR'S PANEL



Fig. 8

ASSEMBLING THE STEERING COLUMN

Fig. 9



MOUNTING THE RIGHT AND LEFT-HAND FENDERS

Fig. 10

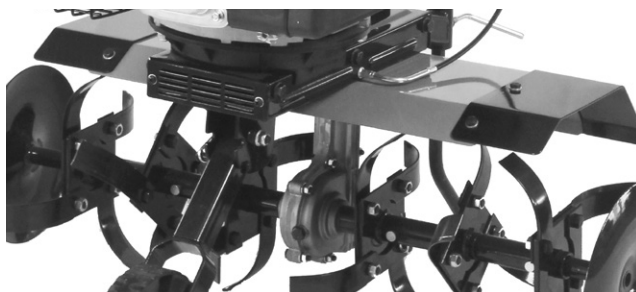

INSTALLING THE CABLE TIES

Fig. 11



MOUNTING THE TRANSPORT WHEEL

Fig. 12



CULTIVATOR OPERATION

COMMISSIONING

During the commissioning:

1. Fill the crankcase with oil (0.6 L)
2. Fill the fuel tank with gasoline (0.4 L for KS 4HP-45; 0.45 L for KS 5HP-65)

Fig 13



USEFUL TIPS

1. To determine the plowing depth, use the coulter at different heights. With the coulter driven deeper into the soil, the cutters also go deep into the soil and the advancement of the device forward slows down considerably.
2. The cultivator speed is determined by adjusting the engine speed. The cutters go deep into the soil with the device in the fixed position.
3. To speed up the cultivator advancement, adjust the coulter higher to lift the cutters.
4. Dry and hard ground may possibly contain big lumps and thus require two passes. Do not process raw soil, because it is difficult to break loose.
5. Immediately release the clutch lever when the cultivator is blocked by foreign objects. Kill the engine, remove obstacles and check the cultivator for deformation and damage. Replace damaged parts as necessary.

FUEL AND OIL

The cultivator requires unleaded gasoline with an octane number of 92. Only use fresh, premium-grade gasoline. Use a funnel (not included) to refuel the device.

Just like without fuel, the cultivator cannot work without oil, so be sure to fill the oil tank before the first start. To do this, place the device on a flat horizontal surface, open the oil tank cap and add the oil to the minimum mark. Use the oil dipstick to check the oil level. The oil filling level must be monitored at all times. Do not exceed or fall short of the oil level. Information on the used engine oil can be found in technical data of the cultivator.

OPERATOR'S PANEL POSITION

1. Loosen the bolt securing the operator's panel.
2. Set the operator's panel to the desired height.
3. Secure the panel with the bolt.

STARTING AND STOPPING THE ENGINE

Before starting the engine, pump up the gasoline by repeatedly pressing the red button (no more than 5 times).

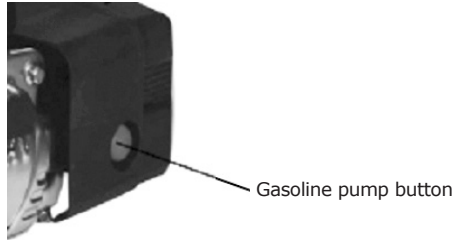

To restart the engine, repeatedly press the red button no more than 3 times. If you press the button more times than required, the ignition plug may be flooded with gasoline and the engine will not start.

To start the engine, move the ignition switch to the "I" (open) position. Grasp the starter handle and slowly pull it until resistance is felt, then completely pull out the starter with a quick movement. Repeat the operation until the engine starts. After the engine has started, allow the rope to wind on the trigger without releasing the starter handle. Move the air choke handle to the "OPEN" position (in the opposite direction).

To kill the engine, move the ignition switch to the "0" (closed) position.

COUPLING OF WORKING PARTS

The engine clutch transmits torque from the engine to the transmission. When the clutch lever is pressed, the belts start to rotate merely to transmit the movement to the chain transmission.

Transport the cultivator to the land plot that needs to be plowed. Start the engine.

By pressing and holding the lever, the cultivator will begin to deepen into the ground while moving forward. Adjust the height of deepening into the ground using the coulters.

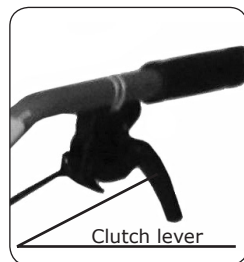
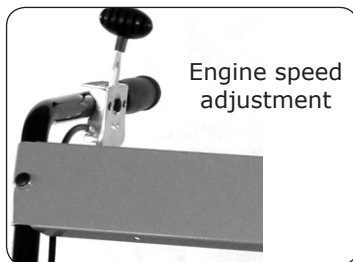

NEXT STEPS

Gradually increase the plowing depth when cultivating hard soil, for which purpose apply pressure on the steering wheel to increase the coulters depth. Always transport the device with the front wheel lowered. After completion of work or in between the plowing sessions, release the clutch lever and stop the engine.

Fig. 14

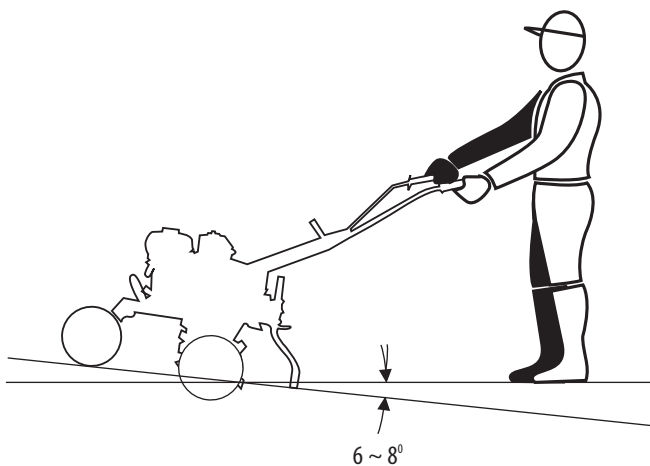

MAINTENANCE

In order to prevent unintentional engine start, disconnect the spark plug wire from the engine during storage and transportation of the device and before all cleaning and maintenance work (such work is allowed only with the engine cooled).

The **Könner & Söhnen** cultivators must be operated, stored and maintained in accordance with the owner's manual. The manufacturer is not responsible for all damages and malfunctions of the device caused by non-compliance with the operating, maintenance and safety instructions for the machine.

THE MANUFACTURER IS NOT RESPONSIBLE FOR:

- The use of non-original lubricants, gasoline and oils;
- The unintended use of the device;
- Losses due to further use of the cultivator with defective parts;
- Technical changes to the device.

MAINTENANCE

All maintenance work listed in section "Maintenance" must be performed on a regular basis. If it is impossible for the machine operator to carry out maintenance work, the machine operator should contact the service center and file an application for maintenance work. The manufacturer is not responsible for any damage caused by failure to perform maintenance work.

SUCH DAMAGE ALSO INCLUDES:

- Damage and losses resulting from the use of non-original spare parts;
- Corrosive damage and other effects of improper storage of equipment;
- Damage caused by maintenance work carried out by unauthorized personnel

CLEANING THE CULTIVATOR

Thorough cleaning and care of the device increases its service life and protects it from damage. After each use, clean the cultivator from soil and dust, remove grass and straw from cutters. Keep the device clean and neat, check for damaged parts, whether the threaded parts are secure.

Do not use jet water to clean seals, engine components and bearings. Otherwise, the cultivator may need costly non-warranty repair.



WARNING - DANGER!



The cultivator is delivered without oil and fuel. Before the first start, be sure to fill the device with oil and gasoline! Use a funnel (not included) to fuel the device.

Oil pollutes soil and groundwater.

Avoid oil leaking out of the crankcase. Dump used oil into the hermetically sealed container. Hand over used oil to waste oil collection point.

REPLACING OR ADDING ENGINE OIL

Follow the maintenance schedule and check the engine oil level on a regular basis. When the oil level drops, add fresh oil to ensure proper operation of the engine. To replace oil, proceed as follows:

1. Ensure that the cultivator is placed on a flat, level surface.
2. Place an oil drain tray under the cultivator engine.
3. Unscrew the drain cap located under the dipstick cap using a 10 mm wrench.
5. Wait for the oil to drain.
6. Replace and tighten the drain cap.

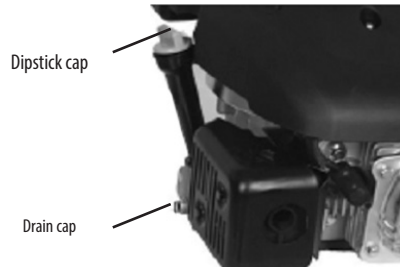

TO ADD OIL, PROCEED AS FOLLOWS:

1. Make sure the device is mounted on a flat, level surface.
2. Unscrew the dipstick cap on the engine.
3. Fill the crankcase with highly refined oil using a funnel.
4. The oil level should be as shown in Fig. 15.

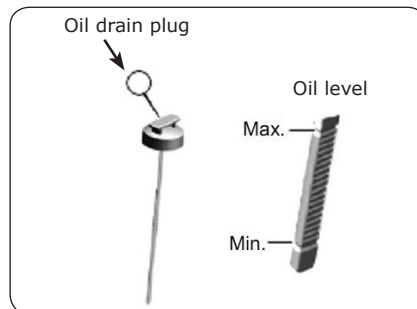

Fig. 15

MAINTAINING THE SPARK PLUGS

The spark plug is one of the most important items to ensure proper and sustainable engine operation. Be sure to check the spark plug on a regular basis: it must be intact, properly gapped and free of deposits.

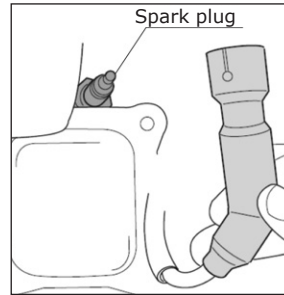

Fig. 16

INSPECTING THE SPARK PLUG

It is recommended to use F7TC spark plugs. To inspect the spark plug, proceed as follows:

1. Remove the cap from the spark plug.
2. Use the spark plug wrench to remove the spark plug.
3. Thoroughly inspect the spark plug for visible damage. Replace it if necessary.
4. Measure the gap: it should be between 0.7 – 0.8 mm.
5. Before reusing the spark plug, thoroughly clean it with a metal brush to remove soil. Be sure to check the gap.
6. Use the spark plug wrench to screw in the spark plug and replace the spark plug cap.

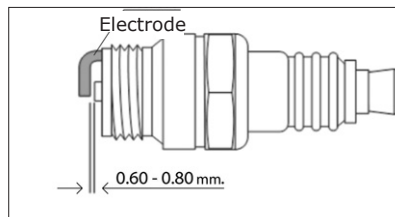

Fig. 17

INTERNAL COMBUSTION ENGINE

To ensure the greatest service life of the engine, monitor the oil level and check oil and air filters for soiling on a regular basis. The cooling fins must be kept clean at all times to ensure sufficient cooling of the engine.

CULTIVATOR ENGINE MAINTENANCE INTERVALS

Unit	Action	At each start	First month or every 20 operating hours	Every month or every 20 operating hours	Every 3 months or every 50 operating hours	Every 6 months or every 100 operating hours	Every year or every 200 operating hours
Engine oil	Level check	✓					
	Replacement		✓		✓		
Air filter	Cleaning		✓	✓			
	Replacement				✓		
Spark plug	Cleaning		✓		✓		
	Replacement					✓	
Fuel tank	Fuel level check	✓					
	Cleaning						✓

AIR FILTER

Regular maintenance of the air filter is necessary to maintain sufficient air flow in the carburetor. Be sure to check it for soiling from time to time as follows:

1. Unscrew the clip on the top cover of the air filter.
2. Remove the sponge filter element from the housing.
3. Remove soil inside the filter housing.
4. Rinse the sponge filter element in warm water and then wipe it dry.
5. Soak a dry filter in fresh engine oil and squeeze it to remove excess oil.
6. The filter must be cleaned every 50 hours of operation of the cultivator.

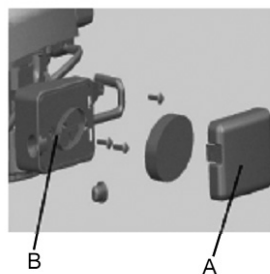

Fig. 18

TROUBLESHOOTING

Несправність	Можлива причина	Усунення несправності
Двигун не запускається	Розмикач ланцюга двигуна в положенні OFF	Привести розмикач ланцюга двигуна в положення ON
	Відсутнє пальне у баку	Додати пальне, прочистити паливопровід
	Паливопровід закупорений	Використовувати завжди свіже пальне марочних сортів, нормальний неетилований бензин
	Погане, старе або забруднене пальне у баку	Очистити паливний бак, паливопровід та карбюратор
	Повітряний фільтр забруднений	Очистити повітряний фільтр
	Штекер дроту свічки запалення від'єднаний від свічки запалення; дріт високої напруги погано закріплені в штекері	Вставити штекер проводу до свічки запалення; перевірити з'єднання між проводом високої напруги та штекером
	Свічка запалення закоптилась або має пошкодження; неправильна відстань між електродами	Очистити або замінити свічку запалення; виставити відстань між електродами
	Двигун "захлинувся" після декількох спроб запуску	Викрутити та просушити свічку запалення, кілька разів смикнути трос при викрученій свічці запалення; регулятор подачі пального у положенні STOP (СТОП)
	Низький рівень оливи в картері	Залити оливу в картер
Тяжкий пуск або зменшена потужність двигуна	Паливний бак забруднений	Очистити паливний бак
	Повітряний фільтр забруднений	Очистити повітряний фільтр
	Свічка запалення закоптилась	Очистити свічку запалення
	Вода в паливному баку та карбюраторі; карбюратор закупорений	Опустошити паливний бак; очистити паливопровід та карбюратор
Двигун перегрівається	Неправильна відстань між електродами свічки запалення	Установити правильну відстань між електродами
	Повітряний фільтр забруднений	Очистити повітряний фільтр
	Ребра охолодження забруднені	Очистити ребра охолодження
	Занадто низький рівень масла у двигуні	Долити моторне масло
Відсутня тяга при натисканні на важель зчеплення	Неправильно встановлений трос зчеплення	Відрегулювати трос зчеплення
Підвищена вібрація під час роботи	Кріплення двигуна послаблено	Затягнути гвинти кріплення двигуна

TRANSPORTATION

Before handling or transporting the cultivator, make sure the ON/OFF switch and fuel valve are in the "OFF" (disabled) position. Install the cultivator horizontally to avoid spilling fuel. Gasoline vapors and spilled gasoline are fire and explosion hazardous!

For convenient transportation of the cultivator, use the original packaging of the cultivator. Secure the cultivator packaging to prevent the cultivator from tipping over during transportation. Drain/work out fuel before handling.

Use the transport wheels to handle the cultivator on site from place to place. Be careful, the cultivator is heavy. Move carefully, do not put your feet underneath the cultivator.



Any contact with parts of the exhaust system or hot engine can cause severe burns or flash. Before handling, transporting or storing the cultivator, allow it to cool down completely.

STORAGE

Before placing the cultivator in storage, carefully inspect the device for possible malfunctions - the machine always has to be ready for operation. Keep the device in a dry, dust-free place, out of the reach of children. It is recommended to store the cultivator at -20 to +40 °C. The cultivator must be protected from direct sunlight and precipitation.

If the cultivator is to be placed in long-term storage (for example, during winter), the following storage conditions must be observed:

- External engine parts, devices, cooling fins must be thoroughly cleaned from soil.
- All moving parts of the cultivator must be oiled or greased.
- The fuel tank and carburetor must be emptied. To do this, work out fuel at idle outdoors.
- Unscrew the spark plug and fill the engine with 3 cm³ of oil.

DISPOSAL

When disposing of the product, keep in mind that the packaging of the cultivator, the accessories and the device are made from recyclable materials.



EC Declaration of Conformity

Nr. 007

The following products have been tested by us with the listed standards and found in compliance with the European Community Machinery Directive 2006/42/EC, Electromagnetic compatibility Directive (EMC) 2014/30/EU, 2000/14/EC Noise Directive.

Manufacturer: DIMAX INTERNATIONAL GmbH
Address: Hauptstr. 134, 51143 Cologne, Germany
Product: Gasoline tiller TM «Könner & Söhnen»
Type/Model: KS 4HP-45, KS 5HP-65

The statement is based on a single evaluation of one sample of above-mentioned products. It does not imply an assessment of the whole production and does not permit the use of the test lab. logo. The manufacturer should ensure that all product in series production are in conformity with the product sample detailed in this report. The applicant should hold the whole technical report at disposal of the competent all the right.

Applied EC Directives: 2006/42/EC Machinery Directive
2014/30/EU Annex II Electromagnetic compatibility Directive (EMC)
2000/14/EC Noise Directive

Applied Standards: EN 709:1997+ A4:209 /AC:2012
EN ISO 14982:2009
EN 55012:2007+A1:2009

2000/14/EC_2005/88/EC Annex VI

For models: KS 4HP-45, KS 5HP-65

Noise: measured Lwa = 90 dB, guaranteed Lwa = 91dB(A)



17

Issued Date: 2017-11-01
Place of issue: Warsaw city
Technical expert: Homenco A.

DIMAX
International
GmbH
Könner-Str. 134 51143 Köln
2017-11-01 11:23:44

We DIMAX INTERNATIONAL GmbH hereby declare that specified above conforms covering European Parliament and Council Directives, 2006/42/EC of May 2006 Machinery Directive, Electromagnetic compatibility Directive (EMC) 2014/30/EU of December 2004, Noise Directive 2000/14/EC of 8 May 2000. The CE mark above can be used under the responsibility of manufacturer. After completion of an EC declaration of Conformity and compliance with all

CONTACTS

Germany

ks-power.de

info@dimaxgroup.de

Poland

ks-power.pl

info.pl@dimaxgroup.de

Ukraine

ks-power.com.ua

sales@ks-power.com.ua
